

LB-250

UN

160

270

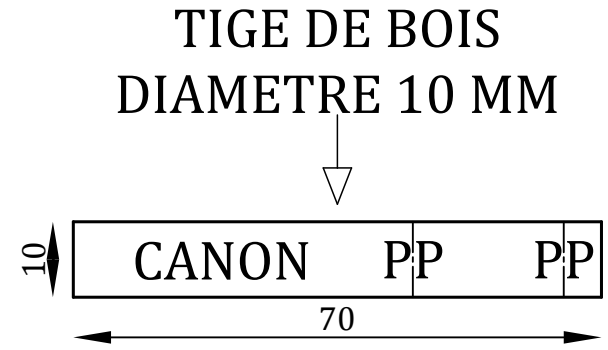
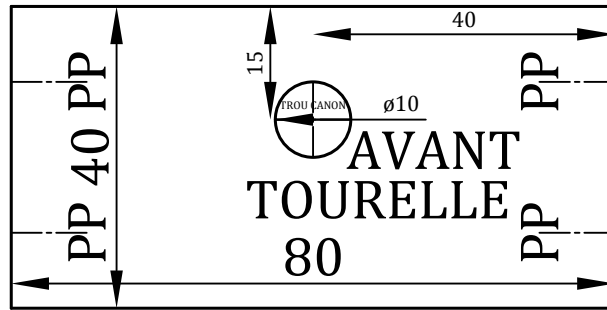

PP=Pré Perçage: DIAM=1.5 mm

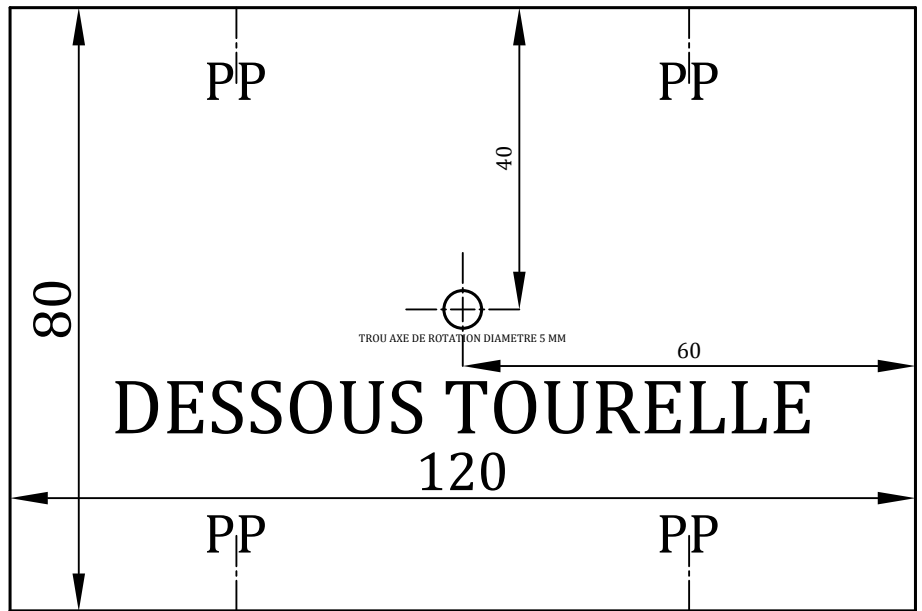
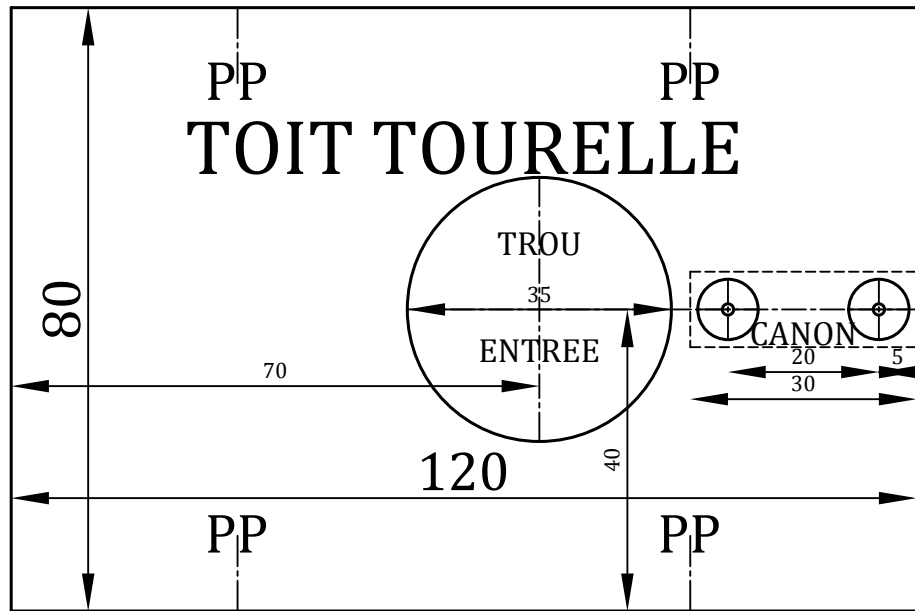

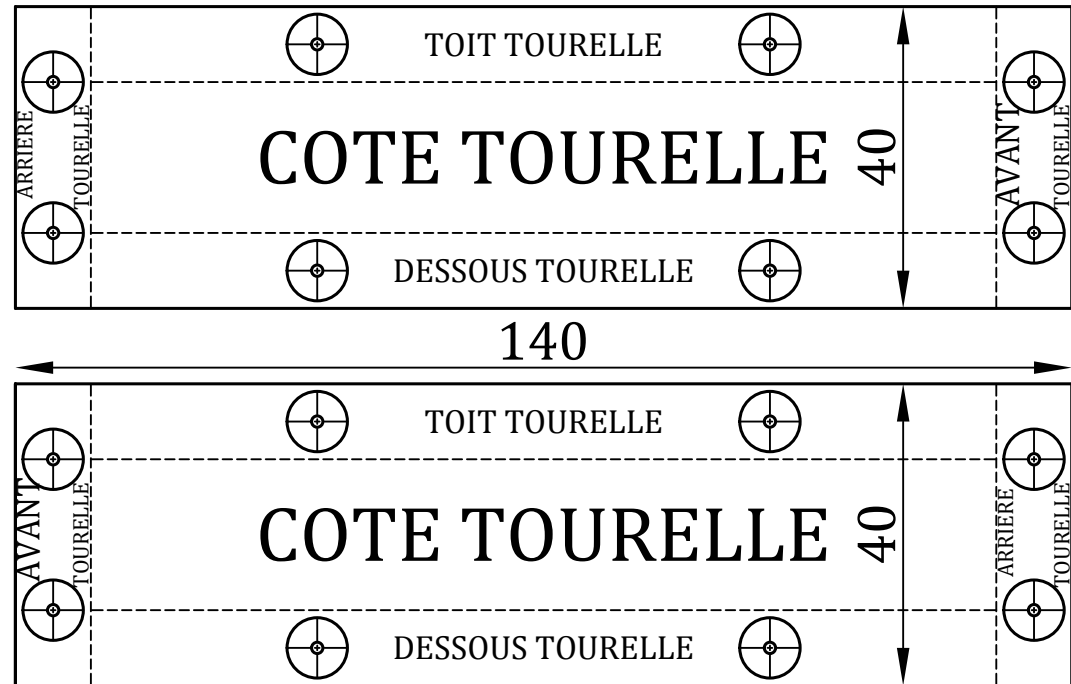
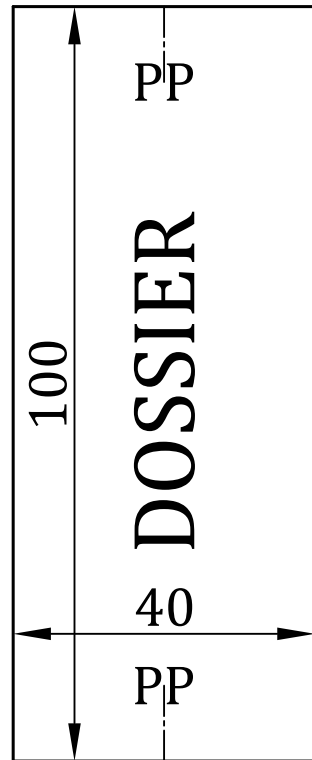
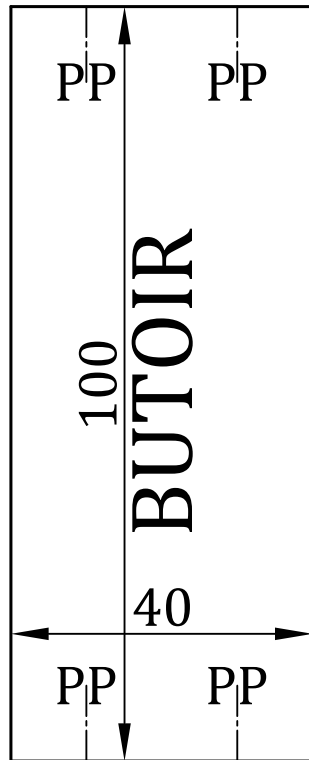

PP=Pré Perçage: DIAM=1.5 mm

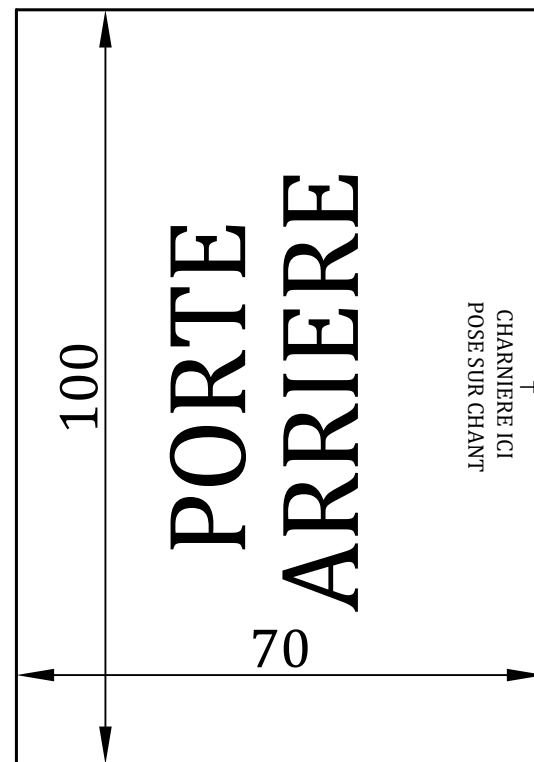
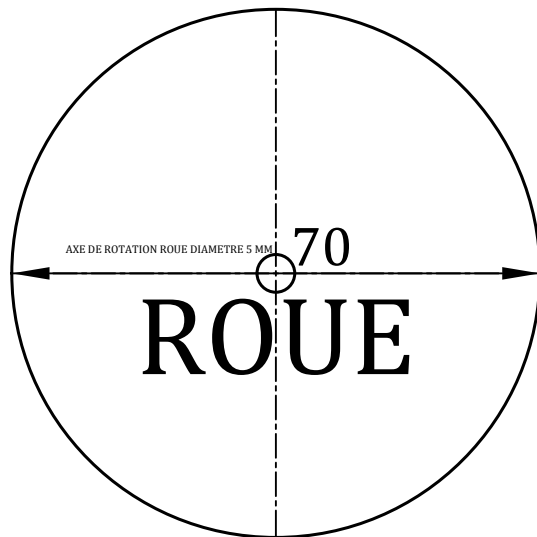
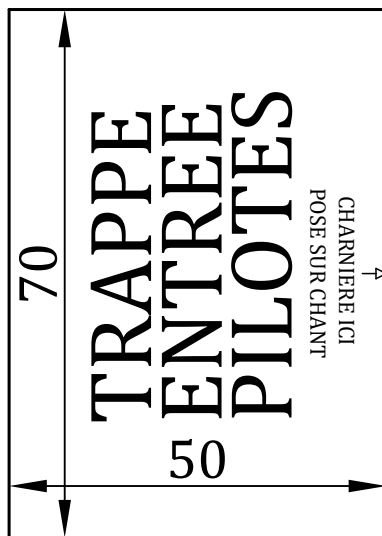
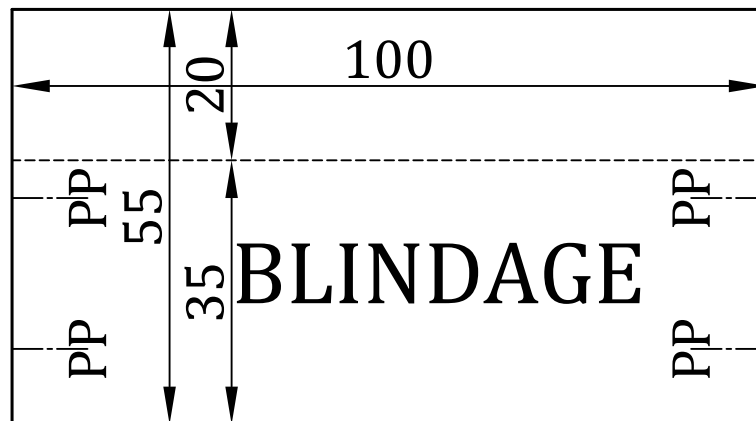
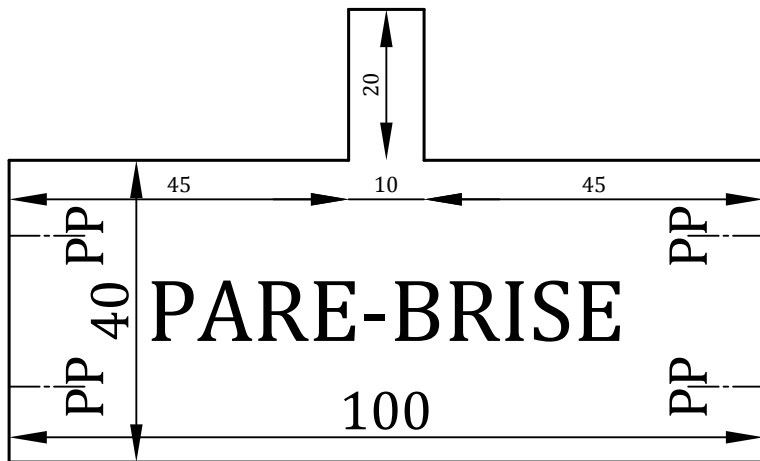

PP=Pré Perçage: DIAM=1.5 mm

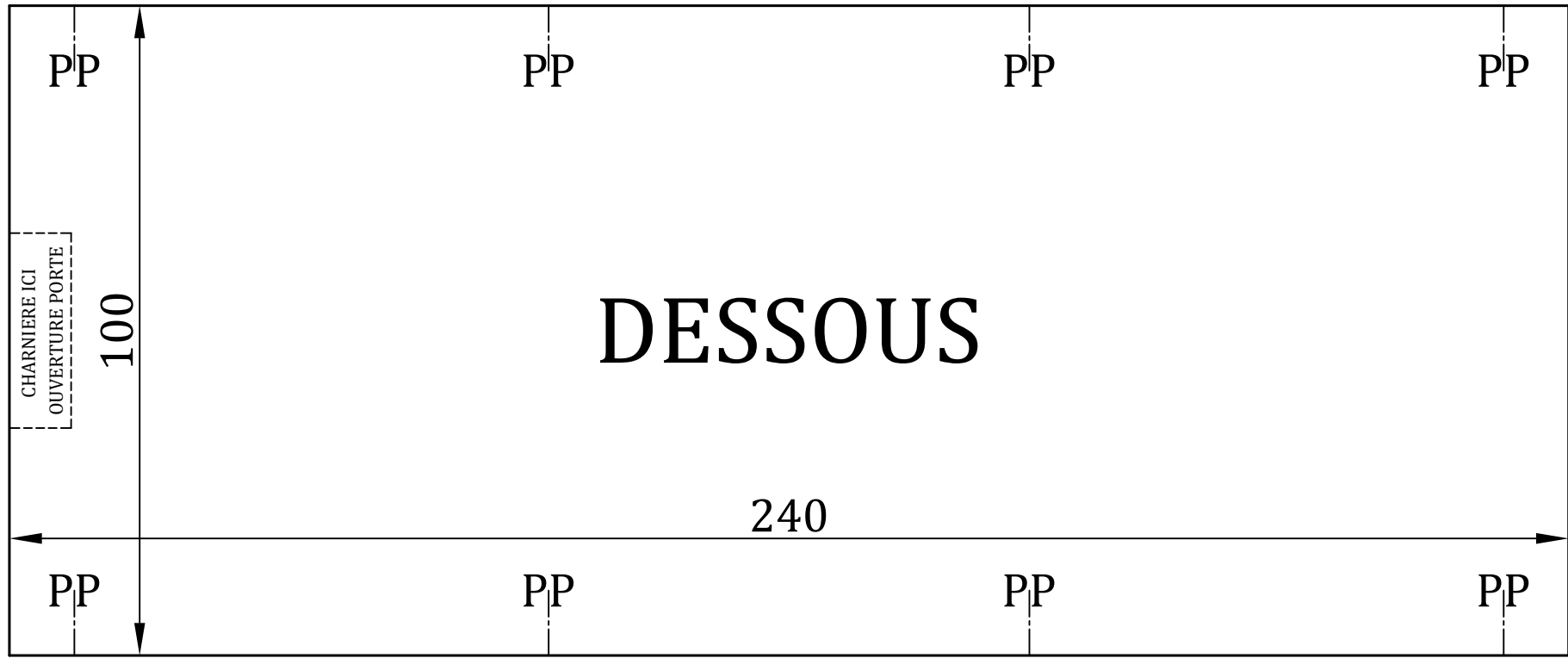

PP=Pré Perçage: DIAM=1.5 mm

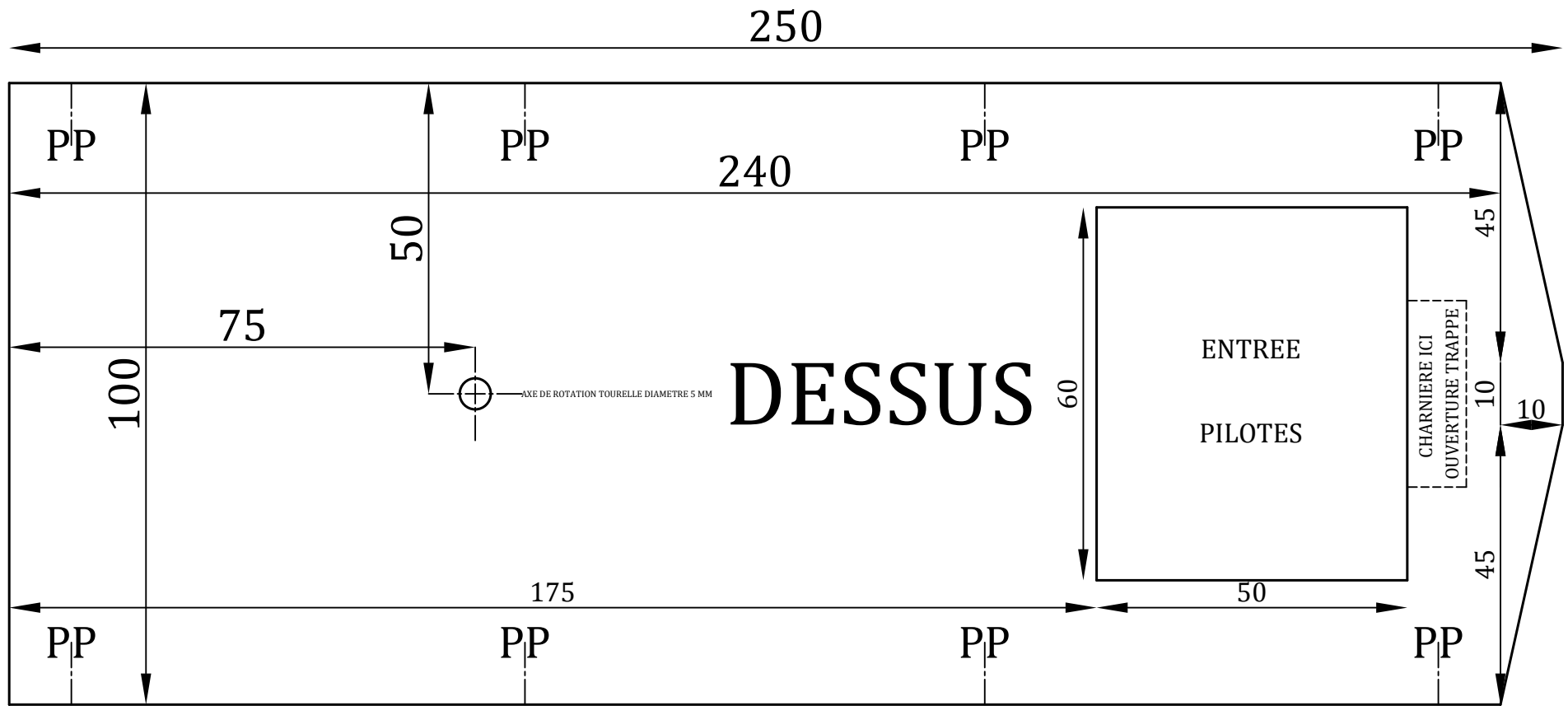

PP=Pré Perçage: DIAM=1.5 mm

TOURELLE
▽

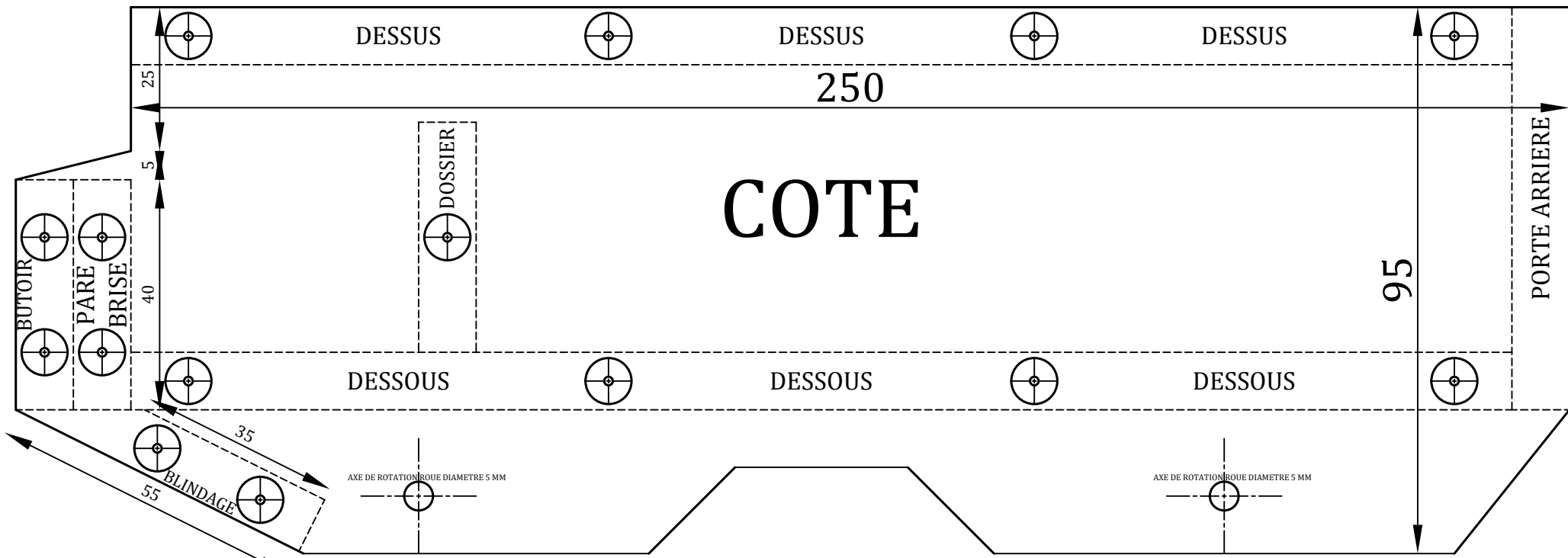

COTE

PP=Pré Perçage: DIAM=1.5 mm

